

Style B

Y-Strainer

Cast Iron (ASTM A 126, Class B)

Class 250 NPT



Cast Iron Y-Strainer

APPLICATIONS

Steam, water, oil or gas where protection from foreign matter in a pipeline is required.

CONSTRUCTION

The Keckley Style B strainers are constructed from rugged cast iron castings that are machined to exacting specifications.

FEATURES

The Keckley Style B features a tapered bushing in sizes 1/4" thru 2" and bolted cover with gasket for sizes 2-1/2", 3" and 4". All Keckley Style B strainers are furnished standard with a NPT blow-off connection and can be supplied with a cast iron blow-off plug upon request.

SCREENS

Standard screens are 20 mesh 304 stainless steel through size 2". Sizes 2-1/2", 3" and 4" are furnished with 1/16" perforated 304 stainless steel screens. All screens are spot welded for maximum strength. Different size perforations and meshes are available in stainless steel, monel, and brass to meet specific media requirements. If media is not indicated, screens for *water* will be supplied.

SELF CLEANING

Self cleaning is accomplished by opening the valve or drain plug connected to the blow-off port. **Warning:** See Maintenance Instructions on page **S6** of the Strainer Information Section for additional precautions and detailed information on servicing the strainer.

WORKING PRESSURES - NON SHOCK

NOM. RATING	MEDIA	1/4" to 4"	8 mm to 100 mm
CLASS 250	STEAM	250 PSI @ 406°F	1724 KPa @ 208°C
	W.O.G.	400 PSI @ 150°F	2759 KPa @ 66°C

GOVERNMENT/MILITARY SPECIFICATIONS

Style B cast iron threaded strainers meet or exceed government specification WW-S-2739 (Supersedes MIL-S-16293).

Style B

Y-Strainer, Class 250 NPT

Cast Iron (ASTM A 126, Class B)

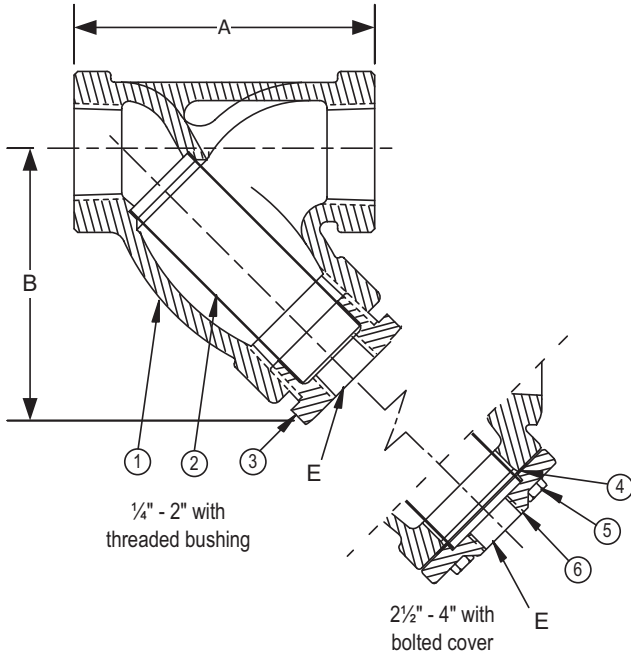

PARTS LIST

ITEM	DESCRIPTION	MATERIAL
1	Body	Cast Iron (ASTM A 126, Class B)
2	Screen	Stainless Steel (304)
3	Bushing	Malleable Iron
4	Gasket*	Composition
5	Cap Screw*	Steel
6	Cover*	Cast Iron (ASTM A 126, Class B)

Optional: Blow-off Plug, Malleable Iron

*2 1/2", 3" & 4" only.

STANDARD SCREENS SUPPLIED

SIZE		SCREEN PERFORATION					
in	mm	FOR LIQUID		FOR STEAM			
		in	mm	AREA	AREA		
1/4 to 2	8 to 50	20 MESH STAINLESS STEEL				49%	
2-1/2 to 4	65 to 100	1/16	1.6	30%	3/64	1.2	33%

Standard screens supplied are for **liquid service**, unless otherwise specified.

Options: Other meshes, perforations, and screen materials are available.

SIZE		DIMENSIONS						WEIGHTS	
in	mm	A		B		E		lbs	kgs
		in	mm	in	mm	in	mm		
1/4	8	3	76	2-5/8	67	3/8	10	2	0.9
3/8	10	3	76	2-5/8	67	3/8	10	2	0.9
1/2	15	3	76	2-5/8	67	3/8	10	2	0.9
3/4	20	4	102	3-5/8	92	1/2	15	3	1.4
1	25	4-7/8	124	4-1/2	114	3/4	20	4.5	2.0
1-1/4	32	5-1/8	130	4-3/4	121	3/4	20	6	2.7
1-1/2	40	5-3/4	146	4-7/8	124	1	25	8	3.6
2	50	7-1/4	184	5-3/4	146	1-1/4	32	15.5	7.0
2-1/2	65	8-7/8	225	7-1/2	191	1-1/4	32	25	11.3
3	80	10	254	8	203	1-1/2	40	36	16.3
4	100	15-1/4	387	12-1/2	318	2	50	95	43.1

[†]This table reflects only the nearest metric equivalents.

Dimensions and weights are for reference only. When required, request certified drawings.

Face to face values have a tolerance in compliance with ASME B16.4.

FLOW COEFFICIENTS

Size	C _v	Size	C _v	Size	C _v
1/2"	9.5	1-1/4"	44.9	2-1/2"	129.7
3/4"	18.7	1-1/2"	61	3"	161.3
1"	30	2"	98	4"	256.2

TOTAL SCREEN AREA

Size	(in ²)	Size	(in ²)	Size	(in ²)
1/2"	5.50	1-1/4"	18.69	2-1/2"	54.13
3/4"	8.59	1-1/2"	23.37	3"	73.51
1"	15.22	2"	36.23	4"	154.98

*See DETERMINING RATIOS on page S5 of the Strainer Information Section for calculating NET FREE AREA of the screen to inside pipe area.

PRESSURE vs. TEMPERATURE CHART

Class 250 NPT Cast Iron (ASTM A 126, Class B)

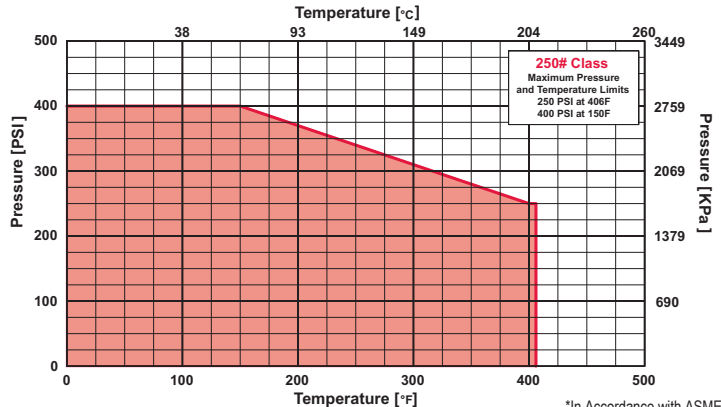

[†]In Accordance with ASME B16.4

PRESSURE DROP CHART

NPT “Y” Pattern Strainers (Styles B, BDI, E150, F150, F300, SB, SB7, SSB and SSB7)

This pressure drop chart is based on the flow of clean water through the Keckley “Y” strainers listed above with screen perforations ranging from 3/64” through 1/8” and is additionally for use with those units equipped with a 20 mesh screen as standard.

TO USE CHARTS:

Find your desired rate of flow (GPM) on the left hand side of the chart. Follow its corresponding horizontal line to the point where it intersects the diagonal line indicating the strainer pipe size. From this point of intersection, follow the vertical line down to the bottom of the chart to determine the approximate pressure drop.

CORRECTION FACTORS:

For finer mesh screens that are backed with a perforated sheet, multiply the pressure drops shown at right by the following:

40 mesh	x 1.2
60 mesh	x 1.4
80 mesh	x 1.6
100 mesh	x 1.7
150 mesh	x 1.8
200 mesh	x 2.0

