

DRAWING NO.
AL 731745

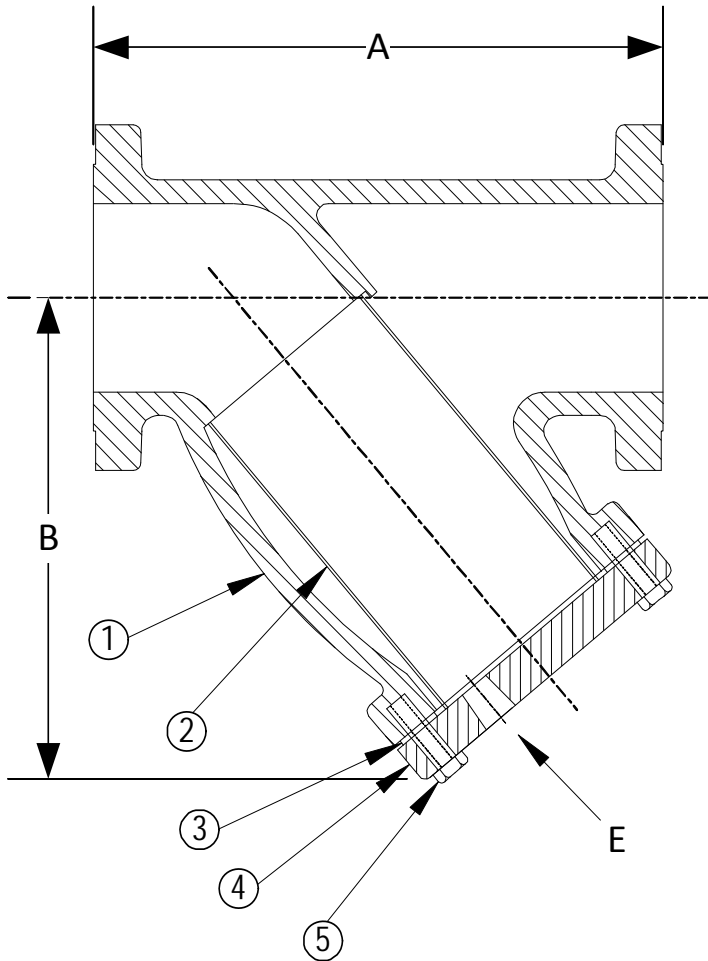

BODY PRESSURE & TEMPERATURE RATINGS - NON SHOCK			
NOM. RATING	MEDIA	2" to 12"	14" and UP
250# R.F. & D. (EX. HEAVY FLANGE)	STEAM	250 PSI @ 450°F	200 PSI @ 406°F
	W.O.G.	500 PSI @ 150°F	300 PSI @ 150°F

PARTS LIST		
ITEM	DESCRIPTION	MATERIAL
1	BODY	CAST IRON (ASTM A 126, CLASS B)
2	SCREEN	STAINLESS STEEL (304)
3	GASKET	COMPOSITION
4	COVER	CAST IRON (ASTM A 126, CLASS B)
5	HEX HEAD CAP SCREWS	STEEL

Optional: Blow-off Plug, Malleable Iron

Product Number [†]	SIZE	DIMENSIONS (in)			COVER		WEIGHT (lbs)
		A	B	E	No. of Bolts	Size of Bolts	
23RFY-CI062P34-FB	2	9-7/8	6-1/4	1/2	4	5/8-11 x 1-1/2	33
21/23RFY-CI-062P34-FB	2-1/2	11-1/4	7-3/4	1	4	5/8-11 x 1-1/2	49
33RFY-CI06234-FB	3	12-1/2	8-1/4	1	4	5/8-11 x 1-1/2	57
43RFY-CI062P34-FB	4	14-5/8	10-1/8	1-1/4	8	5/8-11 x 1-3/4	106
53RFY-CI125P34-FB	5	18	12-1/2	1-1/4	8	3/4-10 x 2	157
63RFY-CI125P34-FB	6	20-3/8	14-3/8	1-1/2	8	3/4-10 x 2	215
83RFY-CI125P34-FB	8	23-7/8	17-1/2	1-1/2	8	3/4-10 x 2-1/4	315
103RFY-CI125P34-FB	10	29-5/8	21	2	12	7/8-9 x 2-1/4	525
123RFY-CI125P34-FB	12	33-3/4	23-5/8	2	12	7/8-9 x 2-1/2	700
143RFY-CI125P34-FB	14	38	27-1/8	2	-	-	1400
163RFY-CI125P34-FB	16	42-3/8	29-1/4	2	-	-	1850

[†]See "Style A Product Number Configuration" for additional options.

STANDARD SCREENS SUPPLIED

SIZE	SCREEN GAGE	SCREEN PERFORATION			
		FOR STEAM	OPEN AREA	FOR LIQUID	OPEN AREA
in		in		in	
2 to 4	28	3/64	33%	1/16	30%
5 to 10	24	3/64	33%	1/8	43%
12	24	1/16	30%	1/8	43%
14 & UP	20	1/8	43%	1/8	43%

Standard screens supplied are for **liquid service**, unless otherwise specified.
Options: Other perforations, meshes, and screen materials are available.

 3400 CLEVELAND SKOKIE ILLINOIS	DRAWING NO. AL 731745
	PART NO.
DIMENSIONAL ASSEMBLY	SCALE: NTS
2" to 16" 250# Flg Style A	DATE: 12/28/2016
MAT'L: Cast Iron	DR. BY DSF
REQ. ---	