

Data Sheet

1279 Duragauge® Pressure Gauge

FEATURES

- Custom dial printing options
- Micrometer adjustable pointer
- **PLUS!**™ Performance option dampens vibration, shock and pulsation effects
- Pressure range from vacuum to 30,000 psi

TYPICAL USES

- Refineries
- Chemical and petrochemical plants
- Offshore oil rigs
- Water and wastewater pressure control
- Pulp and water
- Mining and metals
- Equipment skids
- Specialized OEM equipment
- Cryogenics



1279
4 1/2" dial size



SPECIFICATIONS

Accuracy:	±0.5% of span (ASME B40.100 Grade 2A)
Size:	4 1/2"
Range:	Vacuum, compound to 30,000 psi
Process Connection Location:	Lower, back, side, top
Process Connection:	1/4 NPT, 1/2 NPT, 3/16-18 UNF-2B Aminco® (high pressure connection)
Case Style:	Solid front with pressure relief back
Window:	Glass (STD.), acrylic, shatter proof glass, non-glare glass (OPT.)
Movement:	Rotary, adjustable, 400 SS, Teflon® coated
Movement Materials:	400 SS, Teflon® coated pinion gear and segment
Dial:	Aluminum, white background, black scale
Pointer:	Micrometer, adjustable, aluminum
Weather Protection:	Dry case: Case not sealed, recommended for weather protected environment only Liquid filled or field fillable: IP66 or NEMA 4X (S&P tube and socket), NEMA 4 (A&R tube and socket) Hermetically sealed: IP66
Dampening Options:	Liquid: glycerin, silicone, Halocarbon®, PLUS! ™ Performance
Mounting:	Stem, surface, flush (STD.), pipe, remote (OPT.)
Approvals:	CRN

WETTED COMPONENTS

Bourdon Tube	Process Connection	Joints
316L SS	316L SS	Welded
316L SS	Steel	Welded
K-Monel® 500	Monel® 400, Steel	Welded
C510 Pho. Bronze	Brass	Silver Brazed

KEY BENEFITS

- Available with a wide variety of accessory and diaphragm seal assemblies
- Available with high process temperature dissipation siphons

MIN/MAX TEMPERATURE LIMITS

Version	Ambient	Process	Storage
Dry	-20 °F to 200 °F (-29 °C to 93 °C)	-20 °F to 250 °F (-29 °C to 121 °C)	-40 °F to 250 °F (-40 °C to 121 °C)
PLUS! ™	-40 °F to 150 °F (-40 °C to 66 °C)	-40 °F to 200 °F (-40 °C to 93 °C)	-40 °F to 150 °F (-40 °C to 66 °C)
Glycerin fill	20 °F to 150 °F (-7 °C to 66 °C)	20 °F to 150 °F (-7 °C to 66 °C)	0 °F to 150 °F (-18 °C to 66 °C)
Silicone fill	-40 °F to 150 °F (-40 °C to 66 °C)	-40 °F to 200 °F (-40 °C to 93 °C)	-40 °F to 150 °F (-40 °C to 66 °C)
Halocarbon® fill	-40 °F to 150 °F (-40 °C to 66 °C)	-40 °F to 200 °F (-40 °C to 93 °C)	-40 °F to 150 °F (-40 °C to 66 °C)

NON-WETTED COMPONENTS

Case	Ring	Pressure Relief Back
Phenolic	Threaded, Polycarbonate (meets UL 94 V-0)	Polycarbonate (Meets UL 94 V-0)

Note: Other than discoloration of the dial and hardening of the gasketing that may occur as ambient or process temperatures exceeds 150 °F, non-liquid-filled gauges with standard glass windows, can withstand continuous operating temperatures up to 250 °F (121 °C). Liquid-filled gauges can withstand 200 °F (93 °C) but glycerin fill and acrylic window will tend to yellow. Accuracy at temperatures above or below the reference ambient temperature of 68 °F (20 °C) will be affected by approximately .4% per 25 °F. Gauges with welded joints will withstand 750 °F (400 °C), 450 °F (232 °C) with silver brazed joints for short times without rupture, although other parts of the gauge will be destroyed and calibration will be lost. For continuous use and for process or ambient temperatures above 250 °F (121 °C), a diaphragm seal or capillary or siphon is recommended.

Data Sheet

1279 Duragauge® Pressure Gauge

ORDERING CODE	Example:	451279	S	SH	04	L	XLL	15#
Dial Size/Model Code								
451279 - 4½" solid front		451279						
System (tube and process connection)								
A - Bronze tube, brass process connection, Max. pressure connection 1,000 psi								
P - K-Monel® 500 tube, Monel® 400 process connection, Max. pressure 30,000 psi								
R - 316L SS tube, steel process connection, Max. pressure 30,000 psi								
S - 316 SS tube, 316L SS process connection, Max. pressure 30,000 psi			S					
Case Design								
S - Solid front case, dry								
SH - Solid front case, dry, hermetically sealed				SH				
SL - Solid front case, liquid filled (glycerin STD.)								
Process Connection Sizes								
02 - ¼ NPT Male, N/A for ranges over 20,000 psi								
04 - ½ NPT Male, N/A for ranges over 20,000 psi					04			
09 - 9/16 18 UNF-2B, Aminco® high pressure fitting, pressures over 20,000 psi (STD.)								
AM - AND 10050-4 (¼ tubing connection)								
RW - SAE 7/16 & 20 Straight thread								
Process Connection Location								
L - Lower						L		
B - Back								
D - Side (3 o'clock)								
E - Side connection (9 o'clock)								
T - Top connection								
Options (If choosing an option(s) must include a "X") (See Table 1 on page 3 for more options)								
GV - Silicone case fill								-X__
GX - Halocarbon® case fill								
LL - PLUS! ™ Performance							LL	
NZ - PLUS! ™ Performance, silicone free								
NH - SS tag wired to case								
PD - Acrylic window (STD. with liquid filled or hermetically sealed cases)								
C4 - Individual calibration chart (in accordance with ASME B40.100:2013. Accuracy traceable to NIST)								
6B - Cleaned for oxygen service								
5G - Attach one accessory to gauge. Applicable to PL02 pressure limiting valve, V01,V02,V03 valves, 1098, 1100, 1198, 2198 siphons, 7001, 7004 needle valves, 1115 capillary, 1106 pulsation dampner, 1112, PD02 pressure snubbers, MDV swivel adapter, 2265 electric warning contact								
Range (coding examples only, see range table on page 3 for all standard ranges)								
Single Scales								
15# - 15 psi								15#
1BR - 1 bar								
1KG - 1 kg/cm²								
100KP - 100 kPa								
Dual Scales								
15#/BR - 15 psi inner scale, 1 bar outer scale								
1BR/# - 1 bar inner scale, 15 psi outer scale								

When selecting a diaphragm seal or isolation ring, refer to the [Min/Max Guide](#) for compatibility with this gauge or scan the QR code to the right.



1279 Duragauge® Pressure Gauge

TABLE 1

CODE	OPTION
AB	Gauges calibrated to compensate for absolute pressure
DA	Dial marking (text marking on the dial)
EP	Maximum pointer (adjustable, N/A with liquid filled or hermetically sealed cases)
HY	Hydrostatic/pneumatic testing (system pressurized to 150% of rated system pressure for 5 minutes. Overload stop STD.)
NG	Non-glare glass (N/A with liquid fill or hermetically sealed cases)
OS	Overload stop
SH	Red set hand, stationary
SG	Safety glass
TS	Throttle screw (STD. with liquid filled, hermetically sealed or PLUS! ™ Performance)
VS	Underload stop
56	Flush mounting ring

STANDARD PRESSURE RANGES					
	psi	bar	kPa	mPa	kg/cm ²
Vacuum	30IMV	N1BR	N100KP	N1MP	N1KG
	-	N1/0.6BR	N100/60KP	0.1/0.06MP	N1/0.6KG
Compound	V/15#	-	-	-	-
	-	N1/1.5BR	N100/150KP	N0.1/0.15MP	N1/1.5KG
	V/30#	-	-	-	-
	-	N1/3BR	N100/300KP	N0.1/0.3MP	N1/3KG
	V/60#	-	-	-	-
	-	N1/5BR	N100/500KP	N0.1/0.5MP	N1/5KG
	V/100#	-	-	-	-
	-	N1/9BR	N100/900KP	N0.1/0.9MP	N1/9KG
	15#	1BR	100KP	0.1MP	1KG
	20#	-	-	-	-
Positive Pressure	-	1.6BR	160KP	0.16MP	1.6KG
	30#	-	-	-	-
	-	2.5BR	250KP	0.25MP	2.5KG
	60#	4BR	400KP	0.4MP	4KG
	-	6BR	600KP	0.6MP	6KG
	100#	-	-	-	-
	120#	-	-	-	-
	-	10BR	1000KP	1MP	10KG
	160#	-	-	-	-
	200#	-	-	-	-
	-	16BR	1600KP	1.6MP	16KG
	300#	-	-	-	-
	-	25BR	2500KP	2.5MP	25KG
	400#	-	-	-	-
	500#	-	-	-	-
	600#	40BR	4000KP	4MP	40KG
	800#	-	-	-	-
	-	60BR	6000KP	6MP	60KG
	1000#	-	-	-	-
	1500#	100BR	10000KP	10MP	100KG
2000#	-	-	-	-	
-	160BR	16000KP	16MP	160KG	
3000#	-	-	-	-	
-	250BR	25000KP	25MP	250KG	
4000#	-	-	-	-	
5000#	-	-	-	-	
6000#	400BR	40000KP	40MP	400KG	
8000#	-	-	-	-	
-	600BR	60000KP	60MP	600KG	
10000#	-	-	-	-	
15000#	1000BR	100000KP	100MP	1000KG	
20000#	-	-	-	-	
-	1600BR	-	160MP	1600KG	
30000#	-	-	-	-	

Data Sheet

1279 Duragauge® Pressure Gauge

DIMENSIONS in [] are millimeters

For reference only, consult Ashcroft for specific dimensional drawings

Dial Size Inches	A	B	C	D	E	F	G	H	J	K	L	T	V	Weight oz/kg
4½	5.81 [147.6]	3.36 [85.3]	5.07 [128.7]	1.60 [40.6]	5.375 [137]	1.62 [41.2]	3.92 [99.6]	0.73 [18.4]	0.94 [23.9]	2.62 [66.7]	0.218 [5.5]	0.62 [15.7]	2.62 [66.7]	2.5 (Dry) 3.5 (L.F.)

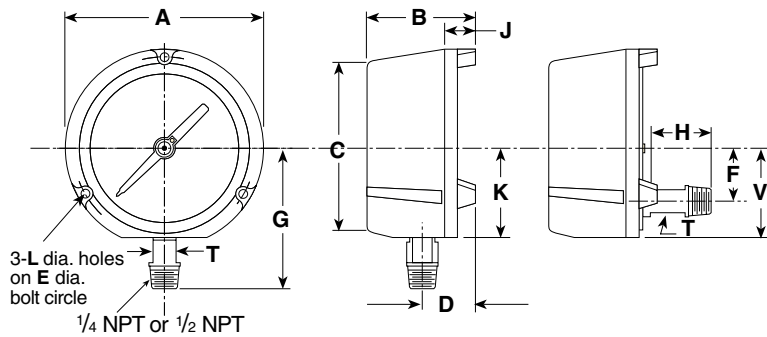

1278M Series Flush Mounting Ring

1278M Series Flush Mounting Ring. Used to flush mount gauge case 1279(*S. Black finish (STD.); Polished SS finish (OPT.))

Gauge Size Inches	Ring O.D.	"A" DIA.	"B" Size of 3 Screws	"C" Size of Washers
4½	6 [152]	5.625 [148]	#10-24 x 1½	7/16 x 17/64 x 5/8

