

Installation & Maintenance Instructions

2-WAY INTERNAL PILOT-OPERATED SOLENOID VALVES
 NORMALLY CLOSED OPERATION — STEAM SERVICE
 3/8" , 1/2" OR 3/4" NPT

SERIES

8222

NOTICE: See separate solenoid installation and maintenance instructions for information on: Wiring, Solenoid Temperature, Cause of Improper Operation and Coil Replacement.

DESCRIPTION

Series 8222 valves are 2-way normally closed, internal pilot-operated solenoid valves designed for steam service. Valves are made of rugged brass or stainless steel with internal parts of stainless steel and elastomers of ethylene propylene or Aflas®. Series 8222 valves may be provided with a general purpose or explosionproof solenoid enclosure.

Notice: Constructions with an "LF" suffix meet the lead free-brass requirement of SDWA 1417 having 0.25% or less lead (Pb) in brass. Due to the variety of operating conditions and applications of these products, the user, through analysis and testing, is solely responsible for making the final selection of the products and assuring that all performance, safety, and warning requirements of the applications are met.

OPERATION

Normally Closed: Valve is closed when solenoid is de-energized; open when energized.

NOTE: No minimum operating pressure differential required.

Manual Operator (optional feature)

Manual operator allows manual operation when desired or during an electrical power outage. To engage manual operator (open the valve), turn stem clockwise until it hits a stop. Valve will now be in the same position as when the solenoid is energized. To disengage manual operator (close the valve), turn stem counterclockwise until it hits a stop.

▲ CAUTION: For valve to operate electrically, manual operator stem must be fully rotated counterclockwise.

▲ ATTENTION: Afin que la vanne fonctionne électriquement, la commande manuelle doit être complètement tournée dans le sens inverse des aiguilles d'une montre.

Relocation of Manual Operator

▲ WARNING: To prevent the possibility of death, serious injury or property damage, turn off electrical power, depressurize solenoid operator and/or valve, and vent fluid to a safe area relocating manual operator.

▲ AVERTISSEMENT: Pour éviter tout risque de décès, de blessure grave ou de dégâts matériels, avant de remettre en place l'opérateur manuel : couper l'alimentation électrique, dépressuriser la vanne et purger le fluide dans une zone sûre.

Manual operator may be relocated at 90° increments by rotating the valve bonnet as follows:

1. See separate solenoid installation and maintenance instructions and follow instructions to loosen solenoid to allow rotation of enclosure.
2. Be sure manual operator stem is counterclockwise.
3. Remove bonnet screws from valve body.
4. Lift valve bonnet slightly and rotate to desired position. Do not rotate the diaphragm assembly with the valve bonnet.

AFLAS® is a registered trademark of the Asahi Glass Co., Ltd

5. Replace bonnet screws and torque in a crisscross manner to 50 ± 5 in-lbs [5,7 ± 0,6 Nm]. Position and tighten solenoid in place, see separate instructions.

▲ WARNING: To prevent the possibility of death, personal injury or property damage, check valve for proper operation before returning to service.

▲ AVERTISSEMENT : Afin de prévenir le risque de décès, de graves blessures ou de dommage matériel, vérifiez le bon fonctionnement de la vanne avant la remise en service.

6. Test operate valve electrically and manually. Be sure valve can be test operated without effecting other equipment.
7. Restore line pressure and electrical power supply to valve.

INSTALLATION

Check nameplate for correct catalog number, pressure, voltage, frequency, and service. Never apply incompatible fluids or exceed pressure rating of the valve. Installation and valve maintenance to be performed by qualified personnel.

Future Service Considerations

Provision should be made for performing seat leakage, external leakage, and operational tests on the valve with a nonhazardous, noncombustible fluid after disassembly and reassembly.

IMPORTANT: Maximum operating pressure differentials are based on temperature-related material limitations. Therefore, do not use valves with a steam source of higher pressure than the nameplate maximum operating pressure differential. Also do not use a pressure reducing valve to reduce steam source to rated pressure because this would result in superheated steam of excessive temperature entering the valve.

Temperature Limitations And Pressure Ratings

For maximum valve ambient and fluid temperatures, refer to chart below or as limited by solenoid approvals. See solenoid installation and maintenance instructions.

Maximum Pressure Rating psi & service (Maximum Operating Pressure Differential)	Coil Class	Max. Ambient Temp. °F	Max. Fluid Temp. °F
50 steam	F or H	77	300

Positioning

This valve is designed to perform properly when mounted in any position. However, for optimum life and performance, the solenoid should be mounted vertically and upright to reduce the possibility of foreign matter accumulating in the solenoid base sub-assembly area.

Mounting

For mounting bracket (optional feature) dimensions, refer to Figure 1.

Piping

Connect piping or tubing to valve according to markings on valve body.

▲ CAUTION: This valve is equipped with ethylene propylene elastomers which can be attacked by oils and greases. Wipe the pipe threads clean of cutting oils.

▲ ATTENTION: Cette vanne est équipée d'élastomères en éthylène-propylène qui peuvent être attaqués par les huiles et les graisses. Essayez les filetages des canalisations pour éliminer les huiles de coupe.

Apply pipe compound sparingly to male pipe threads only. If applied to valve threads, the compound may enter the valve and cause operational difficulty. Avoid pipe strain by properly supporting and aligning piping. When tightening the pipe, do not use valve or solenoid as a lever. Locate wrenches applied to valve body or piping as close as possible to connection point.

▲ CAUTION: To protect the solenoid valve, install a strainer or filter, suitable for the service involved, in the inlet side as close to the valve as possible. Clean periodically depending on service conditions. See ASCO Series 8600 and 8601 for strainers.

▲ ATTENTION: Afin de protéger l'électrovanne ou l'actionneur, installer une crépine ou un filtre adapté le plus proche possible en amont de l'électrovanne ou de l'actionneur. Nettoyer périodiquement le filtre en fonction des conditions d'utilisation. Se référer aux séries 8600 et 8601 pour les crépines.

MAINTENANCE

▲ WARNING: To prevent the possibility of death, serious injury or property damage, turn off electrical power, depressurize solenoid operator and/or valve, and vent fluid to a safe area before servicing.

▲ AVERTISSEMENT: Pour éviter tous danger de mort, de blessure grave ou de dommage matériel, avant d'intervenir sur la vanne, couper le courant, purger la vanne dans une zone sécurisée.

NOTE: It is not necessary to remove the valve from the pipeline for repairs.

Cleaning

All solenoid valves should be cleaned periodically. The time between cleanings will vary depending on the medium and service conditions. In general, if the voltage to the coil is correct, sluggish valve operation, excessive noise or leakage will indicate that cleaning is required. In the extreme case, faulty valve operation will occur and the valve may fail to open or close. Clean valve strainer or filter when cleaning the valve.

Preventive Maintenance

- Keep the medium flowing through the valve as free from dirt and foreign material as possible.
- While in service, the valve should be operated at least once a month to insure proper opening and closing.
- Depending on the medium and service conditions, periodic inspection of internal valve parts for damage or excessive wear is recommended. Thoroughly clean all parts. If parts are worn or damaged, install a complete ASCO Rebuild Kit.

Causes Of Improper Operation

- **Incorrect Pressure:** Check valve pressure. Pressure to valve must be within range specified on nameplate.
- **Excessive Leakage:** Disassemble valve and clean all parts. If parts are worn or damaged, install a complete ASCO Rebuild Kit.

Valve Disassembly

1. Disassemble valve in an orderly fashion. Use exploded views for identification and placement of parts.
2. Remove solenoid, see separate instructions.
3. Unscrew solenoid base sub-assembly and remove core spring from top of core assembly.
4. For valves made of stainless steel (Figure 2) with a manual operator, unscrew manual operator body. Then remove bonnet gasket, stem retainer, stem assembly and stem gasket.
5. For valves made of brass (Figure 3) with a manual operator, it is not necessary to disassemble manual operator for normal maintenance (cleaning). However, if a rebuild kit is being installed, remove stem pin, manual operator stem, stem spring, and stem gaskets.
6. Remove bonnet screws, valve bonnet, core/diaphragm sub-assembly and body gasket.
7. All parts are now accessible for cleaning or replacement. If parts are worn or damaged, install a complete ASCO Rebuild Kit.

Valve Reassembly

1. Reassemble valve using exploded views for identification and placement of parts.
 2. Lubricate all gaskets with Molykote®111 Compound or equivalent high-grade silicone grease.
 3. Position body gasket and core/diaphragm sub-assembly in valve body. Locate bleed hole in core/diaphragm sub-assembly approximately 45° from valve outlet.
 4. Install core spring in top of core assembly. Wide end of core spring in core first; closed end protrudes from top of core.
 5. Replace valve bonnet and bonnet screws on valve body. Torque bonnet screws in a crisscross manner to 50 ± 5 in-lbs [5,7 ± 0,6 Nm].
 6. For valves of stainless steel construction (Figure 2) with a manual operator proceed as follows:
 - A. Install stem gasket on stem assembly and into manual operator body.
 - B. Position stem retainer on manual operator body. Be sure captive spacer on stem assembly is on the Outside of the stem retainer.
 - C. Install bonnet gasket and manual operator body. Then torque manual operator body to 175 ± 25 in-lbs [19,8 ± 2,8 Nm].
 - D. After assembly, operate manual operator to be sure there is no misalignment or binding. If binding occurs, loosen manual operator body and move stem retainer slightly clockwise. Re-torque and check for proper operation. Then rotate manual operator stem counterclockwise as far as possible.
 7. For valves of brass construction (Figure 3) with a manual operator, proceed as follows:
 - A. Install outer stem gasket and inner stem gasket on manual operator stem as shown.
 - B. Install stem spring, and stem assembly with gaskets into valve bonnet.
 - C. Push stem assembly into valve bonnet; align stem pin hole and install stem pin.
 - D. Operate manual operator to be sure there is no misalignment or binding. Then rotate manual operator stem counterclockwise as far as possible.
 8. Replace bonnet gasket and solenoid base sub-assembly. Torque solenoid base sub-assembly to 175 ± 25 in-lbs [19,8 ± 2,8 Nm].
 9. Install solenoid, see separate instructions and make electrical hookup.
- ▲ WARNING: To prevent the possibility of death, personal injury or property damage, check valve for proper operation before returning to service. Also perform internal seat and external leakage tests with a nonhazardous, noncombustible fluid.**
- ▲ AVERTISSEMENT: Afin d'éviter le risque de mort, de blessure ou de dommage matériel, vérifier le bon fonctionnement de l'électrovanne avant de la remettre en service. Contrôler aussi les fuites externe et interne avec un fluide non dangereux.**
10. Restore line pressure and electrical power supply to valve.
 11. After maintenance is completed, operate the valve a few times to be sure of proper operation. A metallic *click* signifies the solenoid is operating.

ORDERING INFORMATION FOR ASCO REBUILD KITS

Parts marked with an asterisk (*) in the exploded view are supplied in Rebuild Kits. When Ordering Rebuild Kits for ASCO valves, order the Rebuild Kit number stamped on the valve nameplate. If the number of the kit is not visible, order by indicating the number of kits required, and the Catalog Number and Serial Number of the valve(s) for which they are intended.

Torque solenoid base sub-assembly to 175 ± 25 in-lbs [$19,8 \pm 2,8$ Nm]

solenoid base sub-assembly *

bonnet gasket *

valve bonnet

core spring *
(closed end of spring protrudes from top of core)

bleed hole

body gasket *

Note:
Constructions with "LF" suffix will be identified with "LF" mark on body and bonnet.

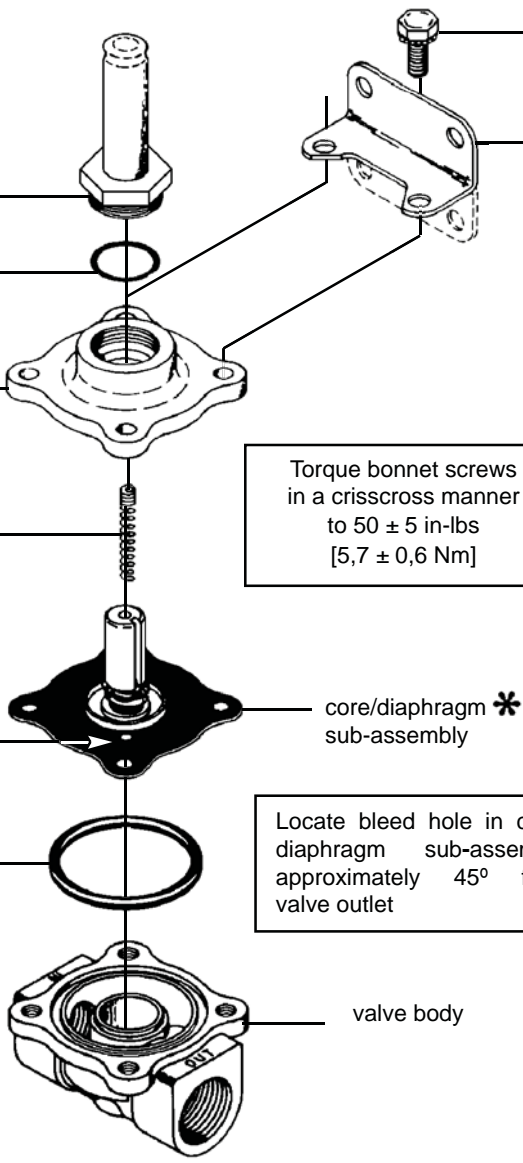

bonnet screw(4)

mounting bracket two positions (optional feature)

Torque bonnet screws in a crisscross manner to 50 ± 5 in-lbs [$5,7 \pm 0,6$ Nm]

Locate bleed hole in core/diaphragm sub-assembly approximately 45° from valve outlet

valve body

Partial view of mounting bracket

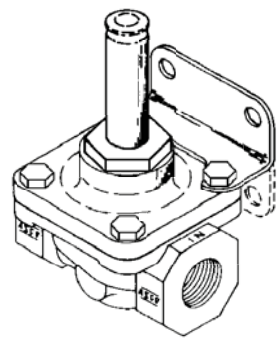
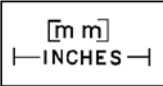
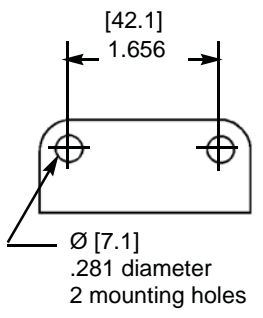

Stainless Steel Construction

Brass Construction

* Indicates that these parts are included in onboard rebuild kit.

Figure 1. Series 8222 Solenoid Valves

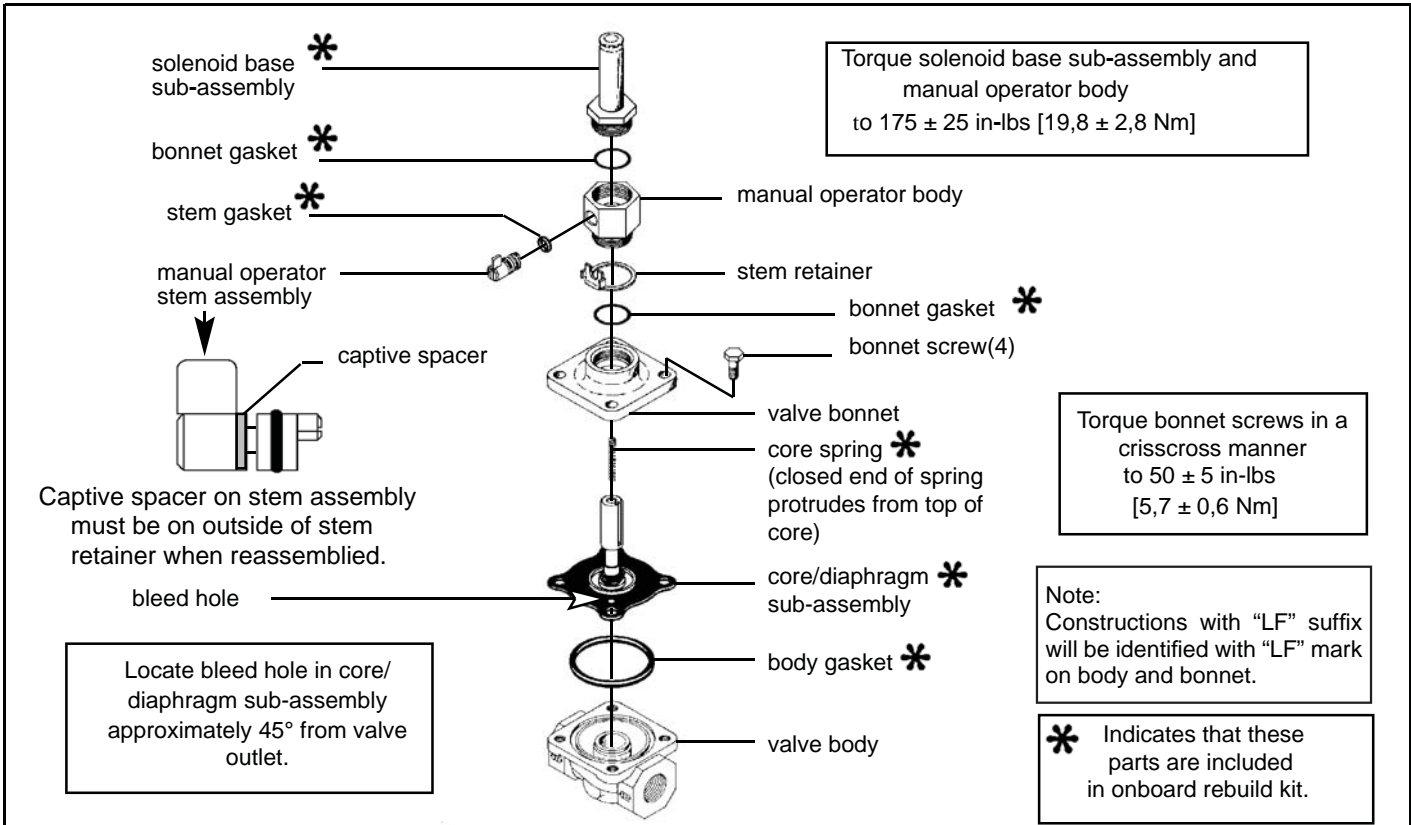

Figure 2. Series 8222 stainless steel construction with manual operator.

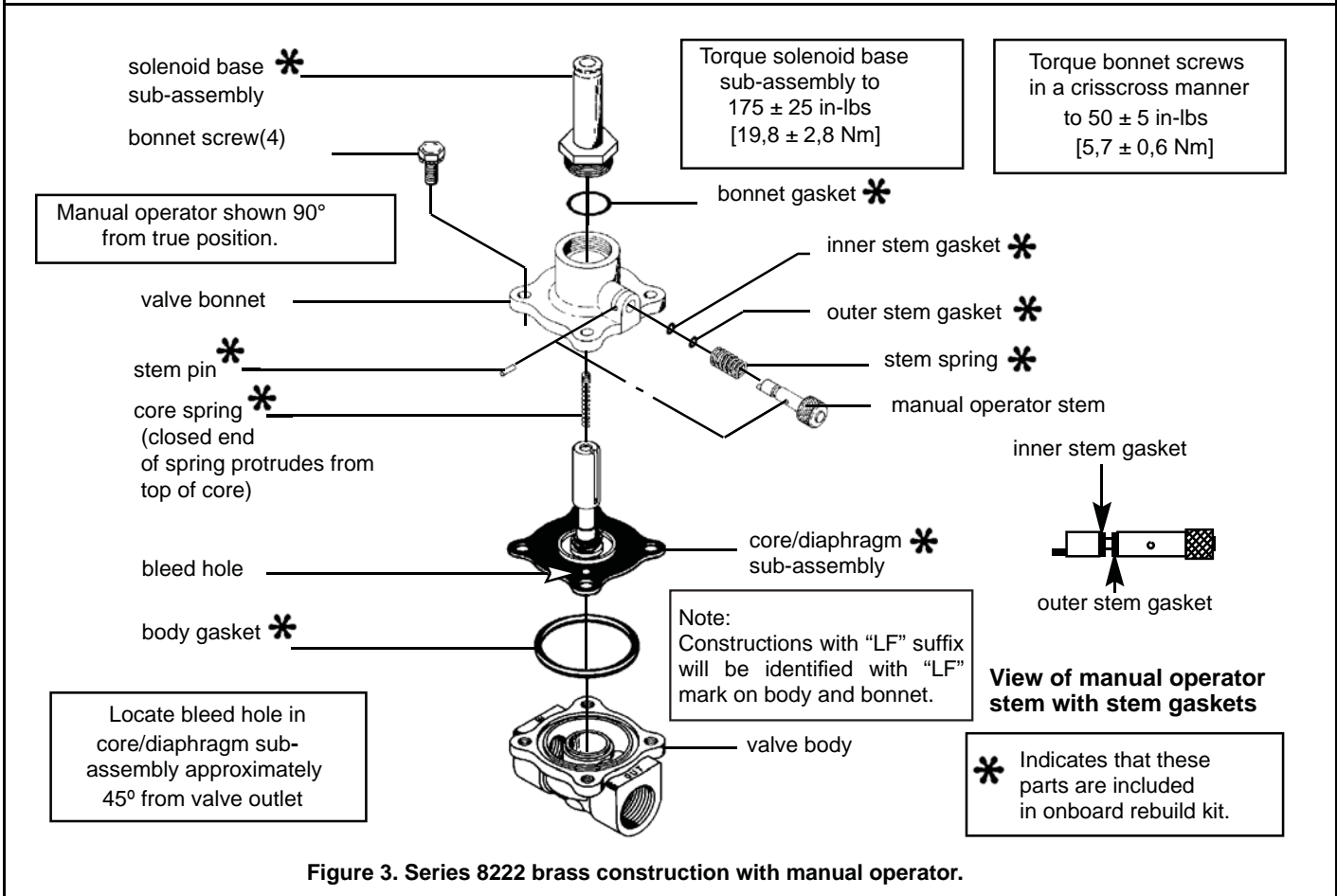

Figure 3. Series 8222 brass construction with manual operator.