

DIMENSIONS & DATA CERTIFIED FOR:

Representative:

Order:

Customer:

Order:

Project:

Requirements:

By:

Date:

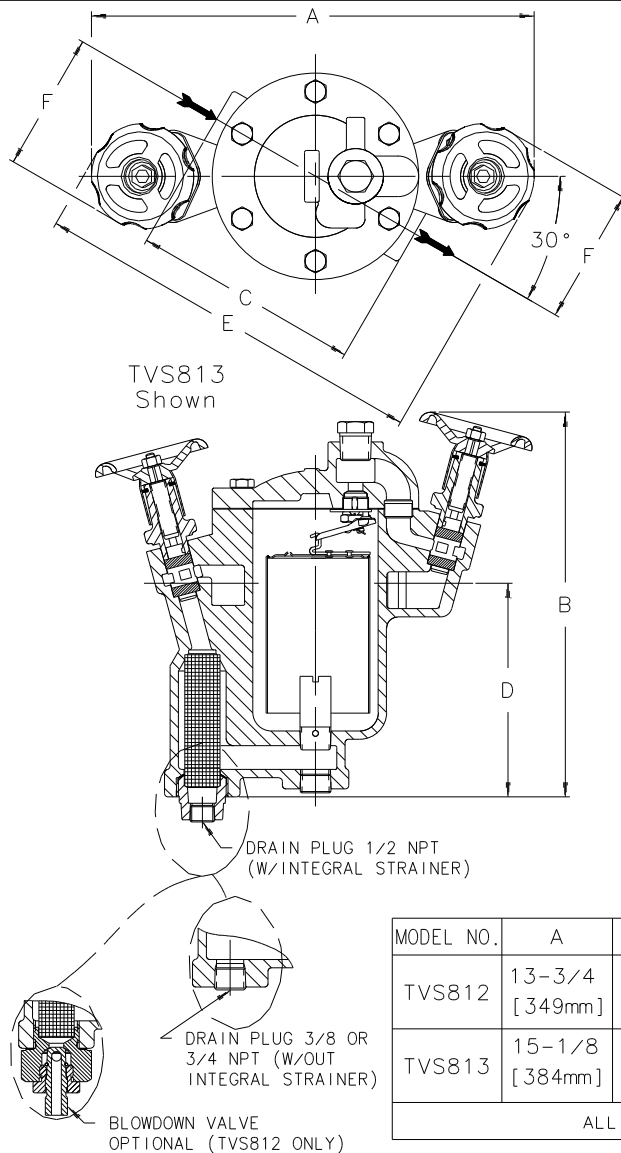

NAME OR PART	MATERIAL
CAP AND BODY	ASTM A48 CL 30
INLET TUBE	STEEL PIPE
GASKET	COMPRESSED NON-ASBESTOS
BOLTS	CARBON STEEL
VALVE & VALVE SEAT	HARDENED STN. STL.
RETAINER, VALVE	STN. STL.
LEVER	
GUIDE PIN ASSEMBLY	
BUCKET	
THIMBLE, BODY	
STRAINER, INTEGRAL (OPTIONAL)	
RETAINER, STRAINER (OPTIONAL)	ASTM A48 CL 30
BUSHING	STEEL
GASKET, STRAINER BUSHING	SOFT STEEL
HANDWHEEL	DUCTILE IRON
NUT	CARBON STEEL
BONNET	ASTM A351 GR CF8M
STUD	ASTM A193 GR B7
DISC SPRING	17-7 PH
NUT	STEEL DIN 934 CL. 10
VALVE PLUG	17-4 PH
WASHER, VALVE	AISI T304 STN. STL.
RING, VALVE	GRAPHITE & STN. STL.
LANTERN BUSHING	ASTM A351 GR CF8M
BLOWDOWN VALVE (OPTIONAL)	T303 STN. STL.
PLUG, DRAIN	STEEL

MAXIMUM ALLOWABLE PRESSURE (VESSEL DESIGN)	250 psig at 450°F [17 bar] at [232°C]
MAX. OPERATING PRESSURE	250 psig [17 bar]
WEIGHT: TVS812 = 25 lbs[11 kgs] TVS813 = 47[21 kgs]	

Dimensions Are In Inches [mm]

MODEL NO.	A	B	C	D	E	F	CONNECTION (NPT)
TVS812	13-3/4 [349mm]	11-3/4 [298mm]	6-1/2 [165mm]	4-3/4 [121mm]	13 [330mm]	4-1/2 [114mm]	1/2 & 3/4 [15 DN & 20 DN]
TVS813	15-1/8 [384mm]	14-1/4 [362mm]	7-3/4 [197mm]	7-1/4 [184mm]	14-3/8 [365mm]	4-7/8 [124mm]	3/4 & 1" [20 DN & 25 DN]

ALL DIMENSIONS ARE WITH THE VALVES IN THE OPEN POSITION

OPTIONS:

CONNECTIONS - NPT OR BSPT
INTERNAL CHECK VALVE
THERMIC VENT BUCKET
BVSW - LIQUID DRAINER
LARGE VENT
INTEGRAL STRAINER
BLOWDOWN VALVE (TVS812 ONLY)



Armstrong International, Inc.
Three Rivers Division
Three Rivers, MI 49093

Armstrong (269) 273-1415 Fax(269) 278-6555
Posted on Armstrong's homepage www.armstrong-intl.com

Product	CD No.	Date
TVS812 & TVS813 INVERTED BUCKET STEAM TRAP	1100	3/8/04
		Rev. E