

DIMENSIONS & DATA CERTIFIED FOR:

Representative:

Order:

Customer:

Order:

Project:

Requirements:

By:

Date:

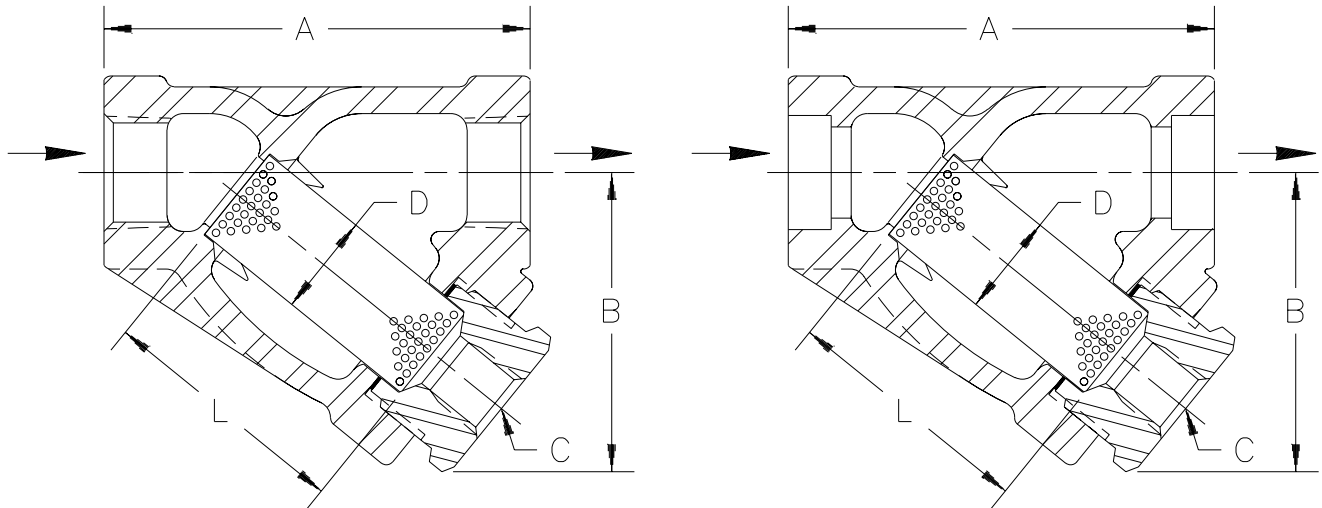

B1SC

B1SW

1" Strainers shown above

Socket Weld Conn. ANSI B16.11
Dimensions A & B ±1/8" [3mm]

DESCRIPTION	DIMENSIONS		
CONNECTION (NPT & SW)	1/2" [DN15]	3/4" [DN20]	1" [DN25]
"A" (FACE TO FACE)	3-23/32" [94mm]	4-3/16" [106mm]	4-31/32" [127mm]
"B" (BOTTOM TO ϕ INLET)	2-11/16" [68mm]	2-15/16" [75mm]	3-1/2" [89mm]
"C" (BLOW DOWN THREAD)	3/8" NPT [DN10]	1/2" NPT [DN15]	
"D" (DIA. OF SCREEN)	13/16" [21mm]	31/32" [25mm]	1-3/16" [30mm]
"L" (LENGTH OF SCREEN)	2-1/16" [52mm]	2-3/8" [60mm]	2-15/16" [75mm]
WEIGHT	2-1/2 lb [1.1 kgs]	3-1/2 lb [1.6 kgs]	5-1/2 lb [2.5 kgs]
MAXIMUM ALLOWABLE PRESSURE (VESSEL DESIGN)	1635 psig at 609°F [112.7 bar at 320.5°C] 2220 psig at 100°F [153 bar at 37.8°C]		

LIST OF MATERIALS	
NAME OF PART	MATERIAL
BODY	ASTM A216 GR. WCB
SCREEN	T304 SS .045" PERF.
GASKET	SOFT STEEL
RETAINER	ASTM A108 GR. 1040 or 1045



Armstrong International, Inc.
Three Rivers Division
Three Rivers, MI 49093
Armstrong (616) 273-1415 Fax(616) 278-6555

Product	CD No.	Date
STRAINER B1SC & B1SW 1/2" - 1" WCB	1047	10/8/96
		Rev. A