



JD & KD Series Ultra-Capacity Float & Thermostatic Steam Trap

Ductile Iron for Horizontal Installation, With Thermostatic Air Vent

For Pressures to 300 psig (21 barg)...Capacities to 142 000 lb/hr (64 400 kg/hr)

Steam Trapping and Steam Tracing Equipment

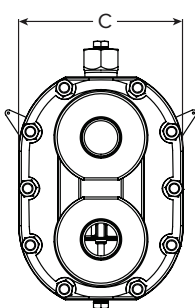

Series JD & KD Cap

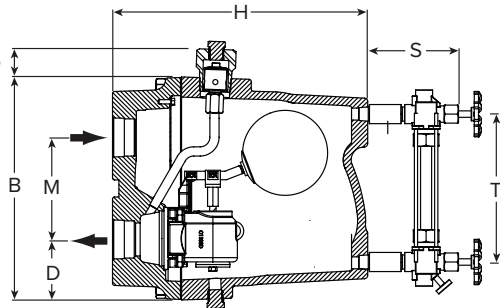

Series KD, F&T shown

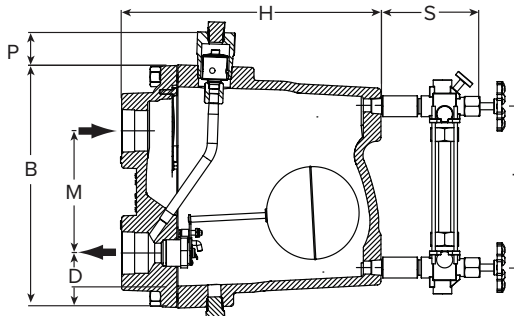

Series JD, F&T shown

Description

The simple, yet rugged, ductile iron construction of the JD & KD Series Ultra-Capacity F&T steam traps offers long, trouble-free service. All floats, valves and seats, and lever mechanisms are constructed of stainless steel.

The integral thermostatic air vent is a balanced-pressure phosphor bronze bellows caged in stainless steel. It is designed especially for heavy-duty industrial applications where highly efficient, uninterrupted service is essential. This balanced-pressure-type air vent will respond to the pressure-temperature curve of steam at any pressure from zero to 300 psig (21 barg). Thus—up to 300 psig (21 barg)—air is vented at slightly below steam temperature.

Maximum Operating Conditions

Maximum allowable pressure (vessel design):

Model JD:	300 psig @ 650°F (21 barg @ 343°C)
Model KD:	300 psig @ 650°F (21 barg @ 343°C)

Maximum operating pressure:

Model 15-JD:	15 psig (1 barg) saturated steam
Model 20-JD:	20 psig (1.3 barg) saturated steam
Model 30-JD:	30 psig (2 barg) saturated steam
Model 75-JD:	75 psig (5.1 barg) saturated steam
Model 125-JD:	125 psig (8.6 barg) saturated steam
Model 175-JD:	175 psig (12 barg) saturated steam
Model 250-JD:	250 psig (17.2 barg) saturated steam
Model 300-JD:	300 psig (20.6 barg) saturated steam
Model 30-KD:	30 psig (2 barg) saturated steam
Model 50-KD:	50 psig (3.4 barg) saturated steam
Model 300-KD:	300 psig (20.6 barg) saturated steam

Maximum operating temperature bellows: 422°F (217°C)

Connections

Screwed NPT and BSPT
Flanged (screw on)

Materials

Body and cap:	ASTM A395 ductile iron
Internals:	All stainless steel
Valve(s) and seat(s):	Stainless steel
Drain plug:	Carbon steel
Thermostatic air vent:	Stainless steel and bronze with phosphor bronze bellows, caged in stainless steel

Options

- Integral vacuum breaker 150 psig (10 barg) maximum. Add suffix VB to model number
- No internal thermostatic air vent for liquid drainer service. Add suffix LD to model number
- Integral flash release for syphon drainage service. Add suffix CC to model number
- Flanged
- Armored gauge glass 310 psig @ 400°F (21 barg @ 204°C)

Specification

Float and thermostatic steam trap, type ... in ductile iron, with thermostatic air vent.

For a fully detailed certified drawing, refer to CD #1302.

How to Order

Pressure	Model	Connection Size	Option
75	JD	8	VB
15	JD	8 = 2"	VB = Vacuum Breaker LD = Liquid Drainer CC = Condensate Controller FLG = Specify type and class of flange GG = Gauge Glass
20			
30			
75			
125			
175			
250	KD	8 = 2"	
300		10 = 2-1/2"	
300		10 = 2-1/2", 12 = 3"	

Special Configurations

Condensate controller with flash release for syphon drainage.

The condensate controller (CC) configuration was developed especially to meet very large capacity needs in applications where condensate must be lifted from the drain point to the trap. Under such conditions—often referred to as syphon drainage—the reduction in pressure that occurs when the condensate is elevated causes a portion of the condensate to flash into steam. Ordinary traps, unable to differentiate between flash steam and live steam, close and impede drainage.

The JD & KD Series condensate controllers (CC) are equipped with a fixed, restricted orifice near the top of the body to bleed off the flash steam (and all air present). This permits the trap to function properly on flashing condensate.

Liquid drainer with back vent for exceptionally high-capacity drainage of liquid from gas under pressure.

The liquid drainer (LD) configuration was developed to meet very large capacity needs in draining water and other liquids from air or other gases under pressure. To prevent air or gas binding, the access port in the top of the body serves as a back vent connection to the equipment being drained. For capacity data, consult Armstrong International or your Armstrong Representative.

JD and KD Series Traps				
Trap Series	JD		KD	
	in	mm	in	mm
Pipe Connection	2	50	2, 2-1/2, 3	50, 65, 80
"B" (Height)	13-1/16	332	13-1/16	332
"C" (Width)	9-11/16	246	9-11/16	246
"D" (Bottom to \varnothing)	2-15/16	75	3-9/16	90
"H" (Length)	13-11/16	348	14-11/16	373
"M" (\varnothing to \varnothing)	6-5/8	168	6	152
"P" (Trap Top to Bellows Cap Top)	1-13/16	46	1-13/16	46
"S" (Gauge Glass width)	4-1/2	114	4-1/2	114
"T" (Gauge Glass height)	8-3/4	222	8-3/4	222
Weight lb (kg)	80 (39)		100 (45)	

Designs, materials, weights and performance ratings are approximate and subject to change without notice. Visit armstronginternational.com for up-to-date information.

JD & KD Series Ultra-Capacity Float & Thermostatic Steam Trap

Ductile Iron for Horizontal Installation, With Thermostatic Air Vent

For Pressures to 300 psig (21 barg)...Capacities to 142 000 lb/hr (64 400 kg/hr)

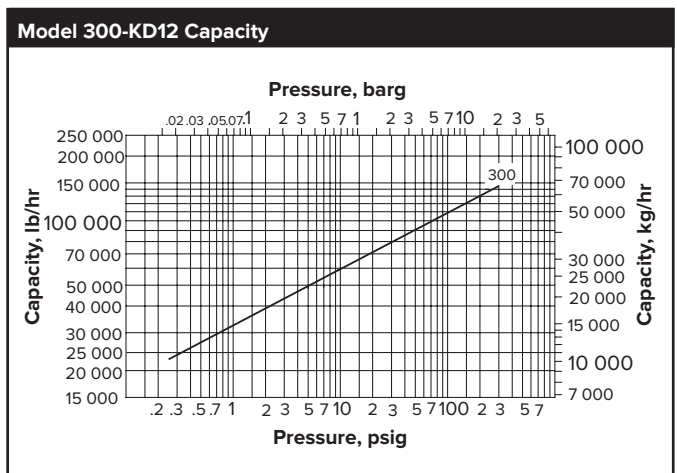
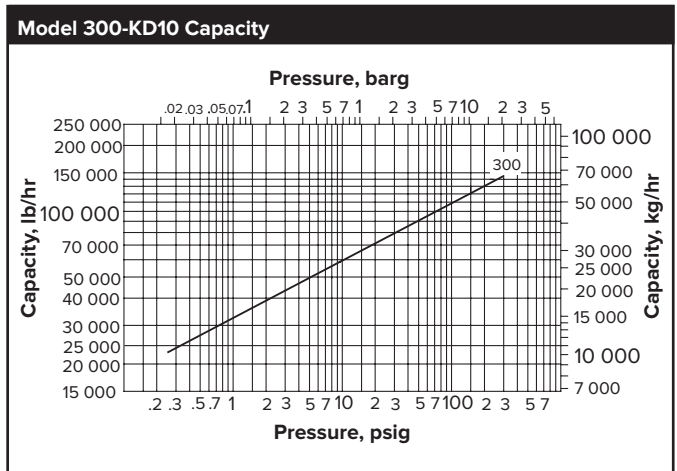
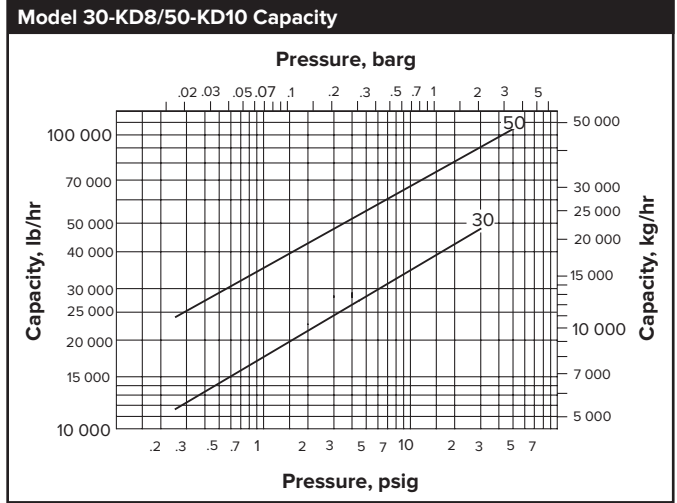
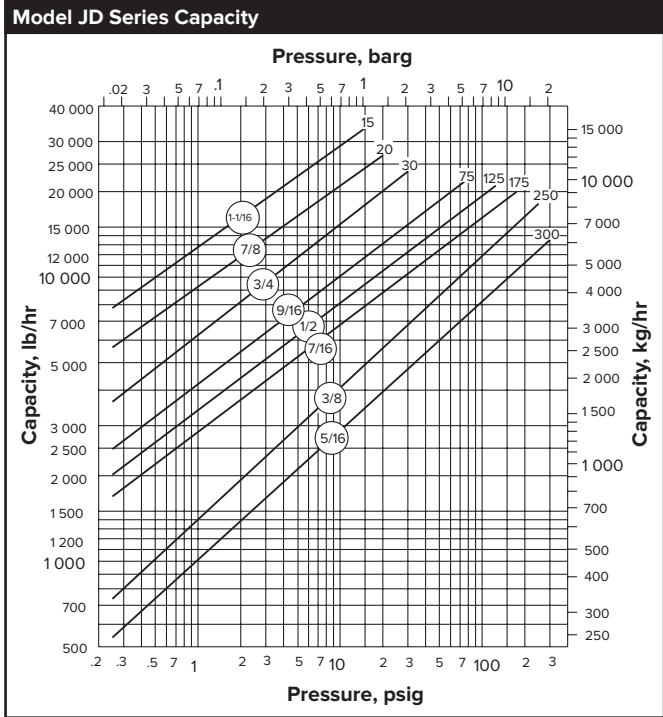

Options

Vacuum Breaker—1/2" (15 mm) NPT

Many times, condensate will be retained ahead of steam traps because of the presence of a vacuum. To break a vacuum, air must be introduced into the system by means of a vacuum breaker.

For maximum protection against freezing and water hammer in heating coils under modulated control, for example, vacuum breakers are recommended in conjunction with freeze protection devices.

Vacuum Breaker			
Size	in	mm	Max. allow. pres.
	1/2 NPT	15	
"B" Pipe Connections	3/8 NPT	10	
"C" Height	1-1/4	32	
"D" Width	7/8 Hex	22 Hex	

