

# ASF Steam Element Installation and Operation Manual

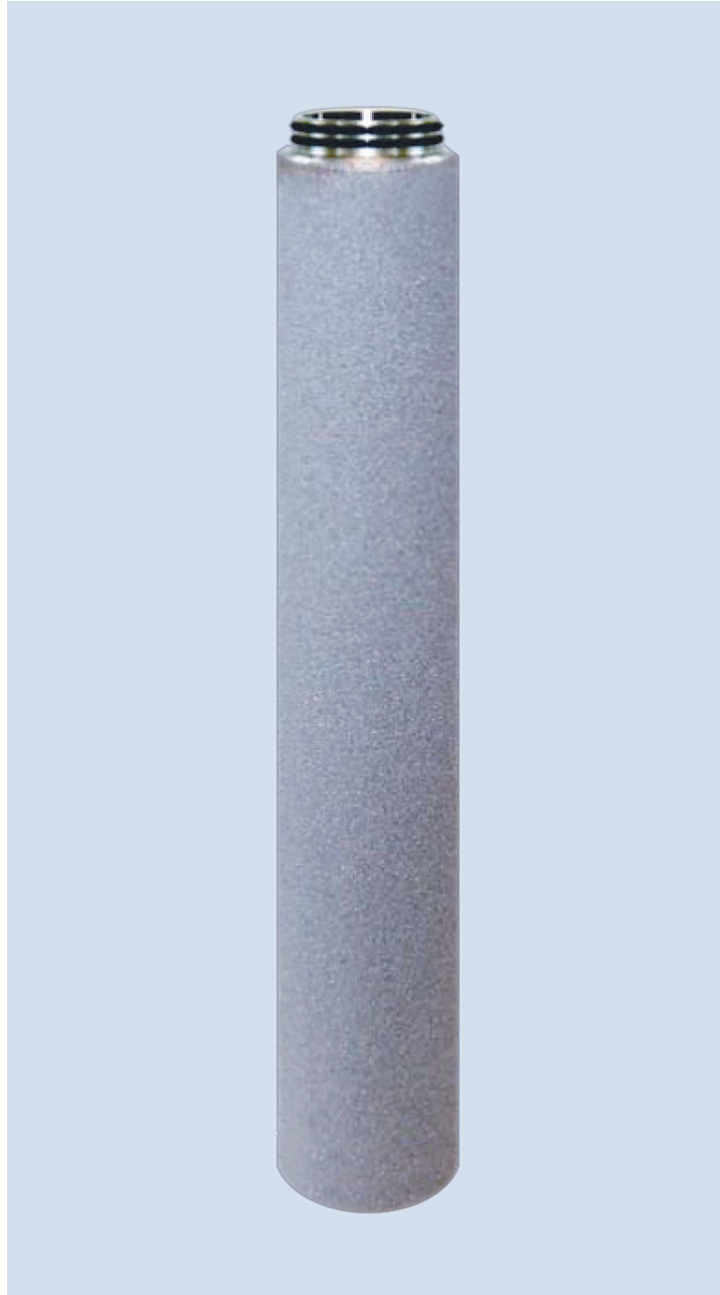

Please read and save  
these instructions



# Product Information

## Product description:

The steam element consists of a regenerable weldless filter pipe made from sintered stainless steel.

## Materials:

Filter medium: Sintered Stainless Steel 316L

End caps: Stainless Steel 304

O-rings: EPDM 291\*

## Retention rates:

1 micron: 100% retention at 1 micron

5 microns: 95% retention at 2 microns

25 microns: 100% retention at 15 microns

## Temperature range:

5°F (-20°C) to 410°F (210°C)\*

\* > 356°F (180°C) other o-rings required

# ASF Steam Element

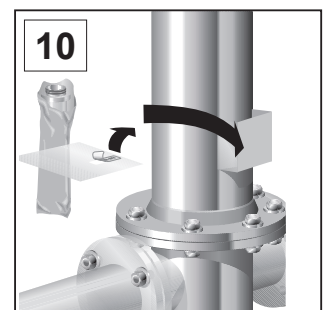
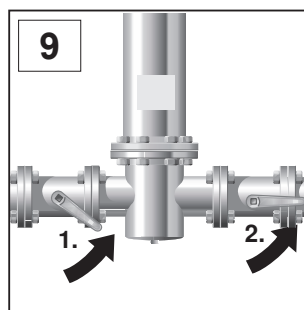
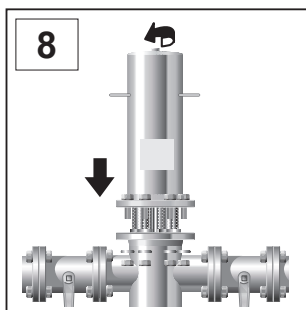
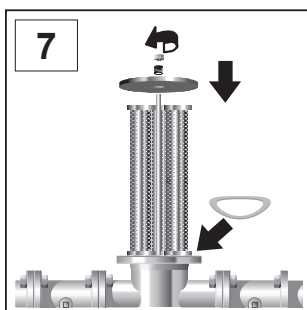
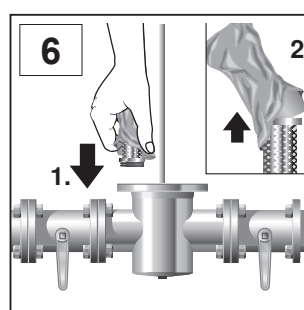
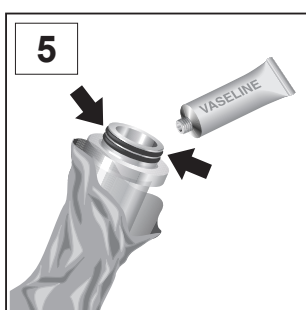
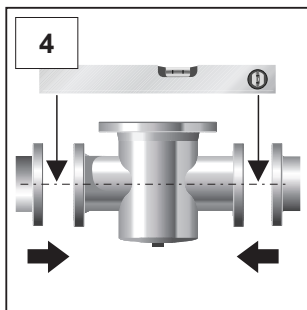
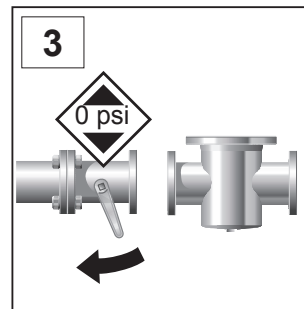
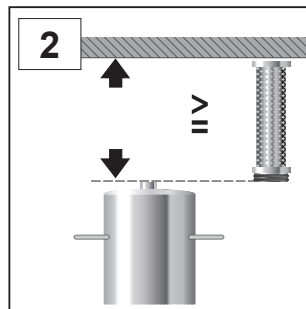
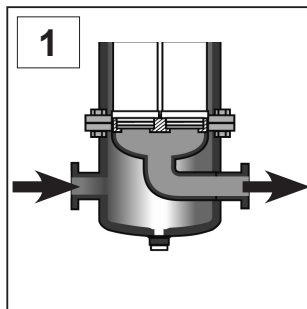

# Limited Warranty and Remedy

Armstrong International, Inc. or the Armstrong division that sold the product (“Armstrong”) warrants to the original user of those products supplied by it and used in the service and in the manner for which they are intended, that such products shall be free from defects in material and workmanship for a period of one (1) year from the date of installation, but not longer than 15 months from the date of shipment from the factory, [unless a Special Warranty Period applies, as listed below]. This warranty does not extend to any product that has been subject to misuse, neglect or alteration after shipment from the Armstrong factory. Except as may be expressly provided in a written agreement between Armstrong and the user, which is signed by both parties, Armstrong **DOES NOT MAKE ANY OTHER REPRESENTATIONS OR WARRANTIES, EXPRESS OR IMPLIED, INCLUDING, BUT NOT LIMITED TO, ANY IMPLIED WARRANTY OF MERCHANTABILITY OR ANY IMPLIED WARRANTY OF FITNESS FOR A PARTICULAR PURPOSE.**

The sole and exclusive remedy with respect to the above limited warranty or with respect to any other claim relating to the products or to defects or any condition or use of the products supplied by Armstrong, however caused, and whether such claim is based upon warranty, contract, negligence, strict liability, or any other basis or theory, is limited to Armstrong’s repair or replacement of the part or product, excluding any labor or any other cost to remove or install said part or product, or at Armstrong’s option, to repayment of the purchase price. As a condition of enforcing any rights or remedies relating to Armstrong products, notice of any warranty or other claim relating to the products must be given in writing to Armstrong: (i) within 30 days of last day of the applicable warranty period, or (ii) within 30 days of the date of the manifestation of the condition or occurrence giving rise to the claim, whichever is earlier. **IN NO EVENT SHALL ARMSTRONG BE LIABLE FOR SPECIAL, DIRECT, INDIRECT, INCIDENTAL OR CONSEQUENTIAL DAMAGES, INCLUDING, BUT NOT LIMITED TO, LOSS OF USE OR PROFITS OR INTERRUPTION OF BUSINESS.** The Limited Warranty and Remedy terms herein apply notwithstanding any contrary terms in any purchase order or form submitted or issued by any user, purchaser, or third party and all such contrary terms shall be deemed rejected by Armstrong.

*Designs, materials, weights and performance ratings are approximate and subject to change without notice.*  
Visit [armstronginternational.com](http://armstronginternational.com) for up-to-date information.



**Armstrong** International  
North America • Latin America • India • Europe / Middle East / Africa • China • Pacific Rim  
[armstronginternational.com](http://armstronginternational.com)